



RECOPAK

INNOVATIVE PACKAGING SOLUTIONS



MODULAR DESIGN

QUICK SIMPLE CHANGE OVER

ROBUST LASER CUT FRAMEWORK

RELIABLE CONSISTENT OPERATION

OPERATOR FRIENDLY CONTROL SYSTEM

100% AUSTRALIAN DESIGNED AND MANUFACTURED

PALLETISER

Machine Description

The Recopak range of palletisers offer a very compact footprint. Maximizing floor space, reduces labour costs, increase your productivity and most importantly eliminate any issues with occupational health and safety.

Our Robotic Palletising solutions provide continuous operation for your palletising process.

Increasing the efficiency of your workplace and reducing the outgoings is the aim of any business and Recopak have your total palletising solutions.

A typical Palletising system can contain:

- An infeed pallet conveyor designed to dispense and transport empty pallets to the load stations and an outfeed pallet conveyor to transport full pallets out of the machine.
- An infeed line conveyor to transport and group cases ready for the robot to collect.
- A robotic arm and gripper to collect the grouped cases and place them on the selected pallets in the desired or required pattern.
- A pallet wrapper to securely wrap the finished pallets with a plastic film ensuring for safe transport is optional.

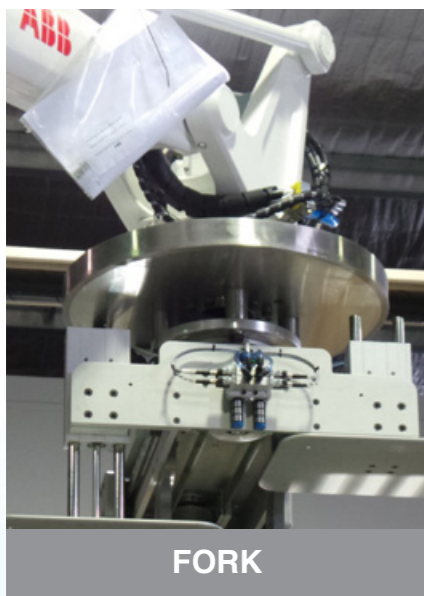

FORK

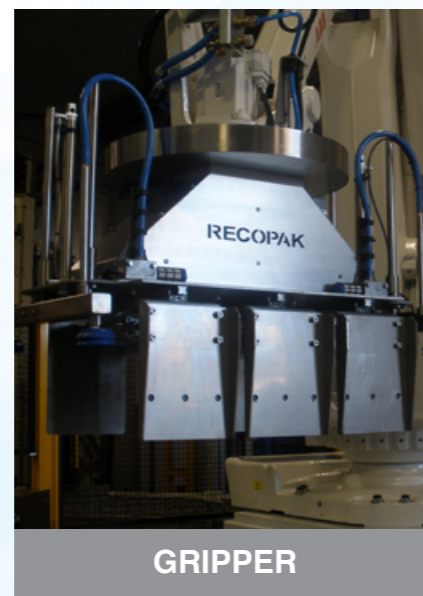

GRIPPER

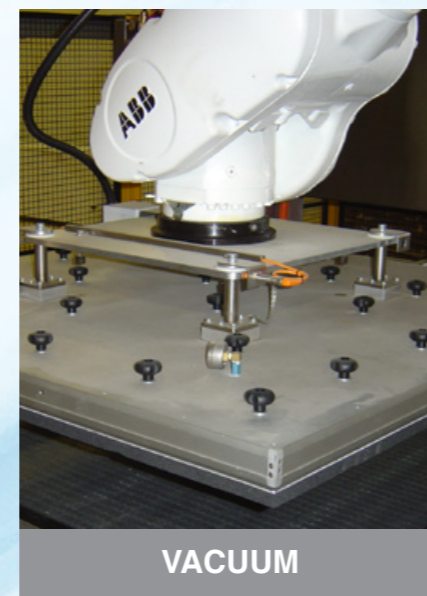

VACUUM

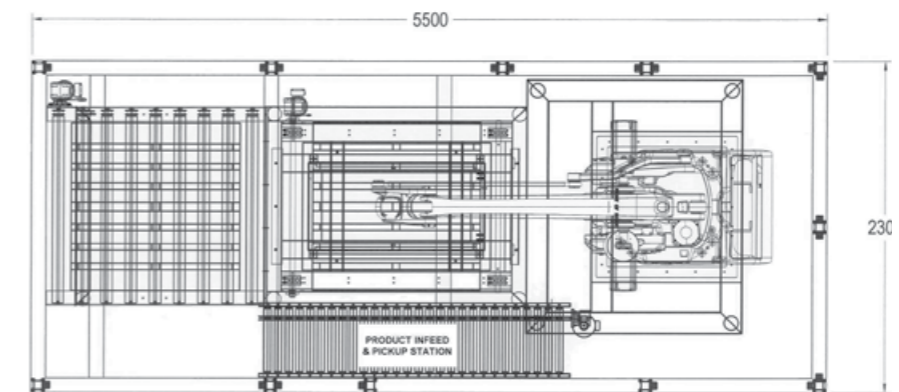
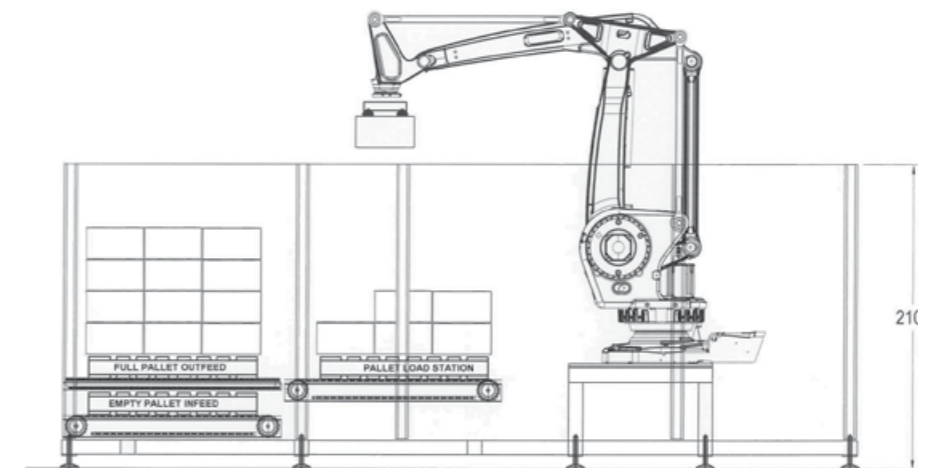

PLEASE NOTE:
Pending application the above schematic is for reference purposes only.
All Palletisers are designed and manufactured to suit the customers specific requirements.

Technical Data:

- Main Voltage:** 400 Volt – 3 Phase (5 wire)
- Control Voltage:** 24 Volt DC
- Control System:** Allen Bradley PLC (Standard)
- Pneumatics:** FESTO (Standard)
- Electrical Load:** Pending application
- Air Supply:** Clean dry air at minimum Pressure of 560 Kpa
- Speed:** Up to 50 Cases per minute pending product and case size

Machine Features:

- Compact Footprint
- Automatic Pallet Dispenser
- Operator friendly HMI Screen
- Integrated Stretch Wrapper available
- Automatic Pallet Labelling systems available
- Varied pick up heads to suit your desired product
- Multiple infeed systems available to cater for different products at any one time

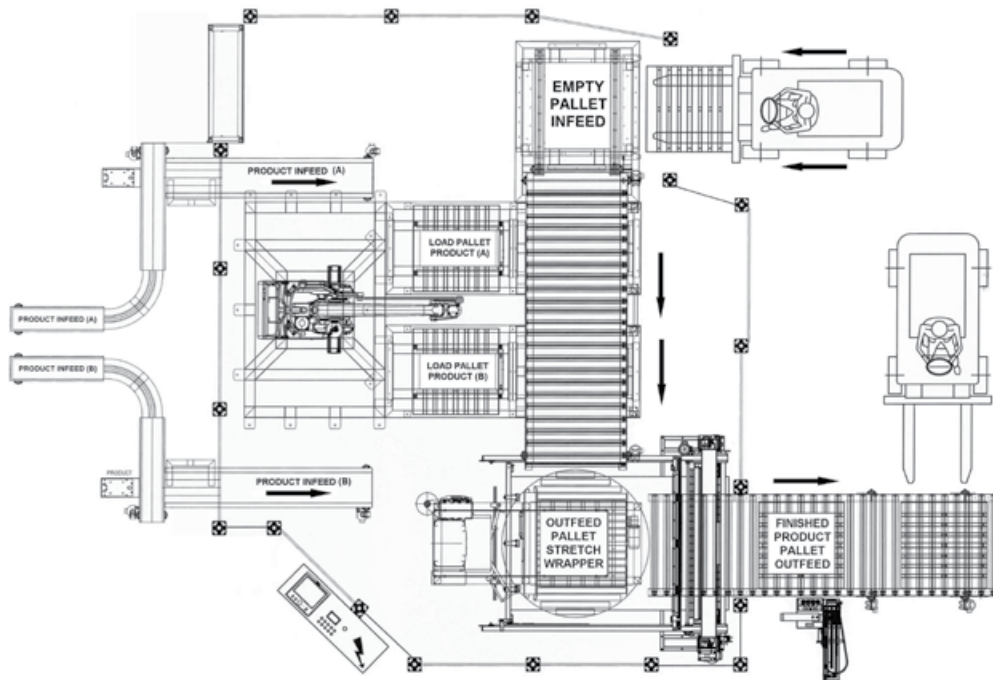

PLEASE NOTE:
Pending application the above schematic is for reference purposes only.
All Palletisers are designed and manufactured to suit the customers specific requirements.

About Recopak

Recopak are the leaders in the design and manufacture of quality packaging machinery. Our product range is continually expanding to suit the ever changing needs of the industry.

In addition to the Recopak range we have carefully selected partners to work with; which enables us to also offer you the most innovative and up-to-date packaging solutions for your company needs.

Recopak employs highly skilled and qualified personnel to provide a complete package from sales, design, installation, after sales technical support and spare parts.

Innovative by design, Recopak machines are finished to the highest standard and have aesthetically pleasing appearance, robust construction, quick - simple size change, accessibility for maintenance and operator safety are a major priority.

Tougher

Packaging equipment needs to have longevity built in. At Recopak our equipment is made to last! We design toughness into every product we manufacture, utilizing the highest quality materials ensures our quality control is second to none.

Smarter

We are manufacturing smarter packaging machinery to make life easier for you and your team....Easy to operate, easy to maintain and designed to keep you on-line for maximum productivity.

Safety

Your most valuable asset is your staff. Our machinery is designed to put their safety first. We comply to all current Australian Safety Standards.

Innovative

Our Research & Development Team continually navigate the globe for the latest innovations and best practices. We incorporate these features into our equipment so you get the latest technological solutions today.

Support

Recopak machines are completely manufactured "In House" by our team of designers, engineers and technicians; that is why we have the expertise to offer our customers complete after sales service and a support that is "second to none".